

[A Practical Guide to 'Free Energy' Devices](#)

Devices Part 5: Last updated: 10th December 2007

Author: Patrick J. Kelly

4. Energy can be taken from "permanent" magnets

Johnson, Camus, Bedini, Ecklin, Coler, Sweet, Bearden, Davidson, Gunderson, Flynn, etc.

Nelson Camus. Nelson Camus built a motor using only permanent magnets as the power source. He stated that it was difficult to adjust the magnets to the correct positions but that when he did, the motor ran uninterrupted for six months. An output power of 300 Watts has been produced. With ferrite magnets some 600 rpm has been achieved and with NIB magnets 3000 rpm. As far as I am aware, nobody else has built a working copy. He states that the moveable aluminium sheets are essential to the operation in addition to acting as a start/stop mechanism.

Here is a sketch of the arrangement:

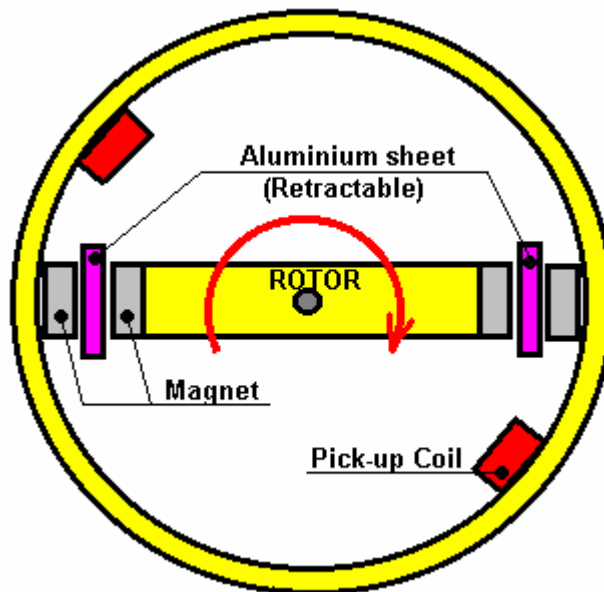

There are two, non-magnetic rotors on the central shaft, one near each end of the shaft. These are adjustable from 85 to 89 degrees to each other, i.e., nearly at right angles to each other but not quite. The thick aluminium plates modify the magnetic field and so are essential for operation of the motor. The pairs of aluminium plates at each end of the cylinder are adjustable separately. The stator magnets are adjustable in height and lateral position and this is done to tune the motor once it has started running. It appears that much skill and perseverance are needed to get this motor operational, but once it has been adjusted, it runs indefinitely.

Details can be seen on the <http://jnaudin.free.fr/html/trmdiag.htm> web site.

John Bedini. John Bedini has produced a very simple motor design which uses only permanent magnets:

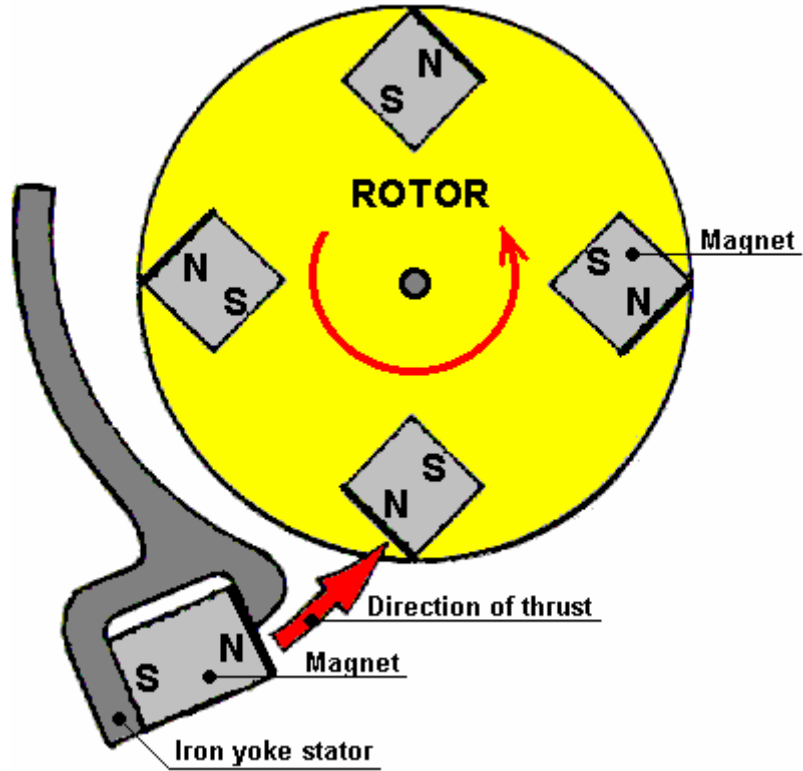

Here, the magnetic field of the stator magnet is altered by the iron yoke. This gives the rotor magnets a push as they pass by, and dampens the opposing thrust which would normally inhibit the rotation.

John W. Ecklin was granted US Patent Number 3,879,622 on 29th March 1974. The patent is for a magnet/electric motor generator which produces an output greater than the input necessary to run it. There are two styles of operation. The main illustration for the first is:

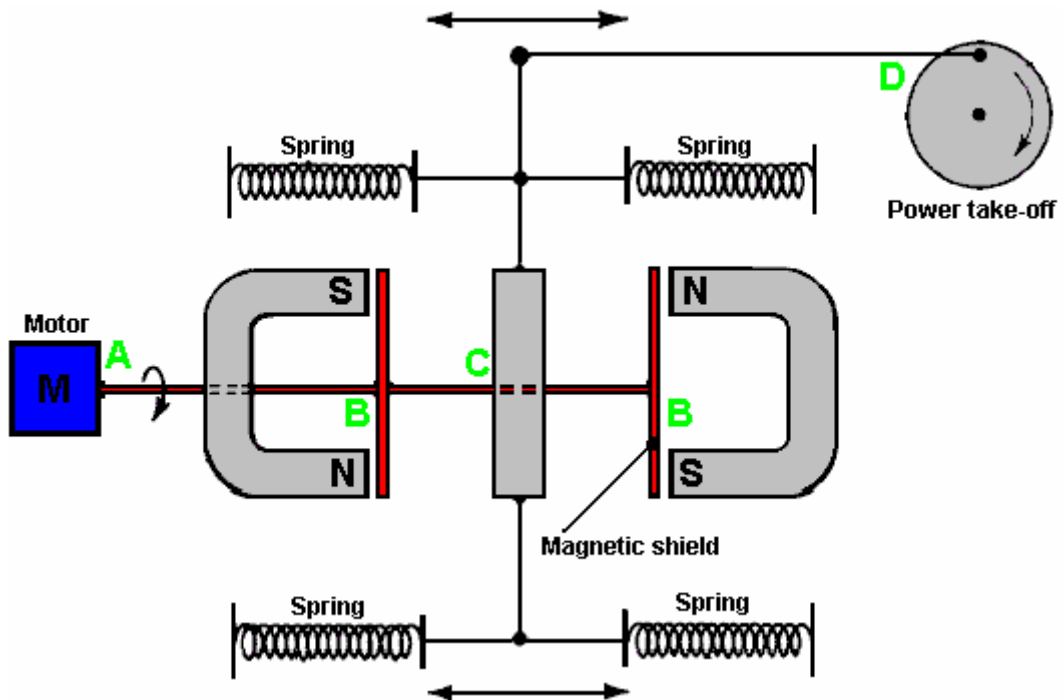

Here, the (clever) idea is to use a small low-power motor to rotate a magnetic shield to mask the pull of two magnets. This causes a fluctuating magnet field which is used to rotate a generator drive.

In the diagram above, the motor at point 'A' rotates the shaft and shielding strips at point 'B'. These rectangular mu-metal strips form a very conductive path for the magnetic lines of force when they are lined up with the ends of the magnets and they effectively shut off the magnet pull in the area of point 'C'. At point 'C', the spring-loaded traveller is pulled to the left when the right-hand magnet is shielded and the left hand magnet is not shielded. When the motor shaft rotates further, the traveller is pulled to the right when the left-hand magnet is shielded and the right hand magnet is not shielded. This oscillation is passed by mechanical linkage to point 'D' where it is used to rotate a shaft used to power a generator.

As the effort needed to rotate the magnetic shield is relatively low, it is claimed that the output exceeds the input and so can be used to power the motor which rotates the magnetic shield.

The second method for exploiting the idea is shown in the patent as:

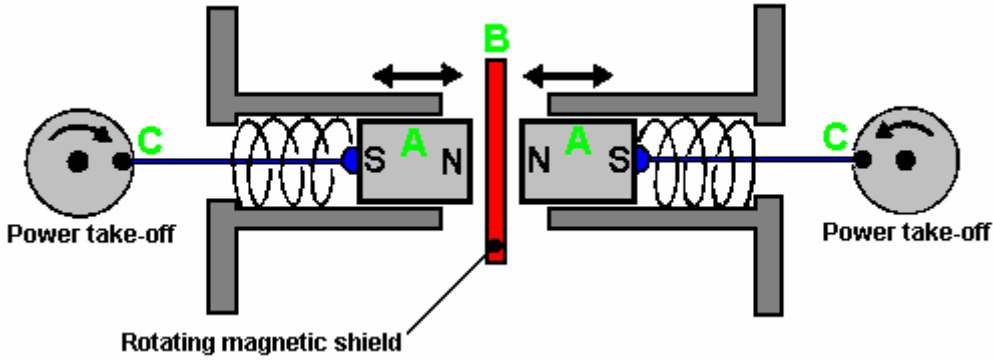

Here, the same shielding idea is utilised to produce a reciprocating movement which is then converted to two rotary motions to drive two generators. The pair of magnets 'A' are placed in a housing and pressed towards each other by two springs. When the springs are fully extended, they are just clear of the magnetic shield 'B'. When a small electric motor (not shown in the diagram) moves the magnetic shield out of the way, the two magnets are strongly repelled from each other as their North poles are close together. This compresses the springs and through the linkages at 'C' they turn two shafts to generate output power.

A modification of this idea is the **Brown-Ecklin Generator**. In this arrangement, the movable magnetic shielding arrangement provides a direct electrical output rather than a mechanical movement:

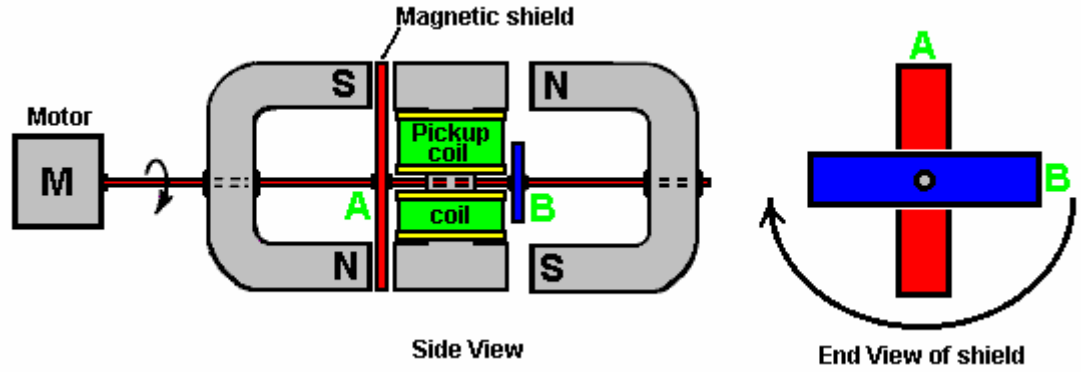

Here, the same motor and rotating magnetic shield arrangement is used, but the magnetic lines of force are blocked from flowing through a central I-piece. This I-piece is made of laminated iron slivers and has a pickup coil or coils wound around it.

The device operates as follows:

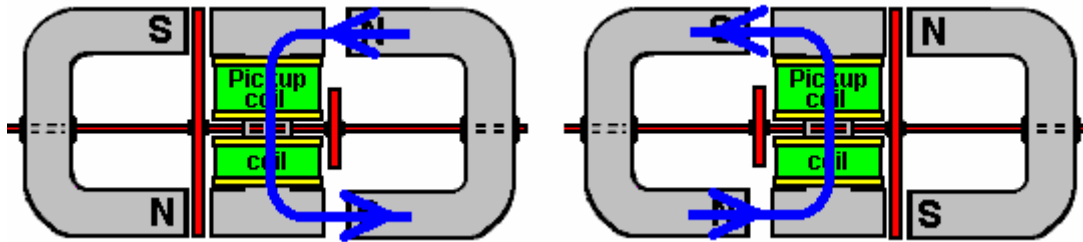

In the position shown on the left, the magnetic lines of force flow **downwards** through the pickup coils. When the motor shaft has rotated a further ninety degrees, the situation on the right occurs and there, the magnetic lines of force flow **upwards** through the pickup coils. This is shown by the blue arrows in the diagram. This reversal of magnetic flux takes place four times for every rotation of the motor shaft.

Invention Intelligence (India). The following design for a permanent magnet motor was published in the April 1977 issue of 'Invention Intelligence' in India:

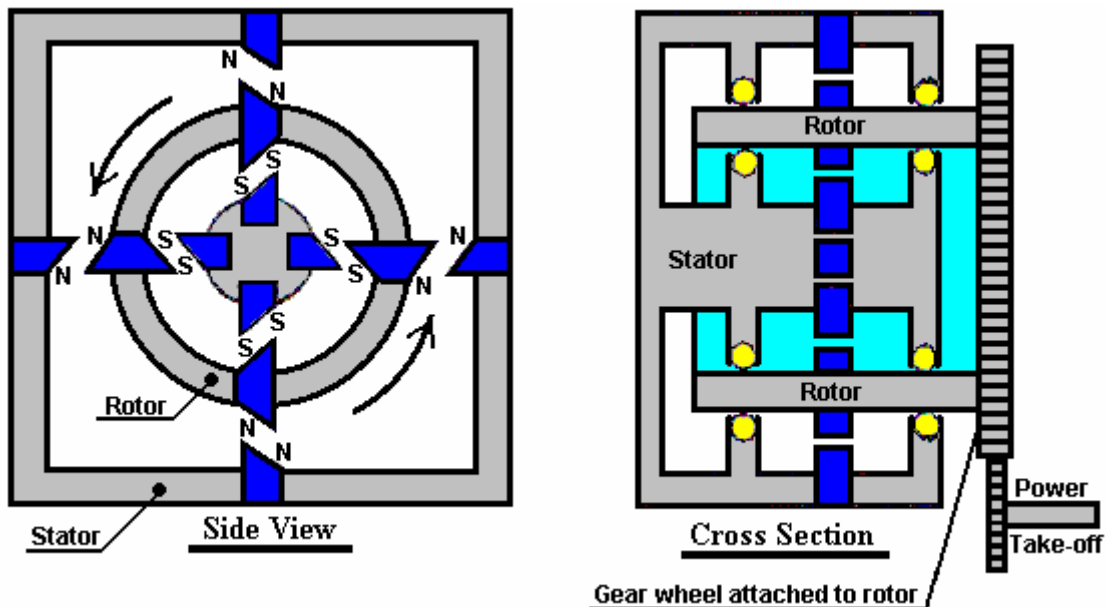

This design relies on the magnetic field of a magnet being distorted by having the pole faces angled at 45 degrees. In the diagram, the magnets are shown in blue and they are mounted in a non-magnetic stator and rotor material shown in grey. The rotor is mounted on two ball races shown in yellow. The theory is that the repulsing forces of the four North-North outer magnet pairs along with the repulsing forces of the four inner South-South magnet pairs should be continuously greater than the North-South attracting forces, thus giving continuous rotation.

It appears most likely that this design is just a theory and that a working model has never been constructed. However, it is possible that this system might work very well, so the information is presented here for interest and possible experimentation. It might be remarked that making the magnet face have a 45 degree angle may well not skew the magnetic field sufficiently to give a big enough imbalance to provide significant drive power. One way to increase the effect might be to use a mu-metal strip along the back of each magnet. Mu-metal is an expensive material which conducts magnetic lines of force in a phenomenal way and so soaks up any magnetism near it:

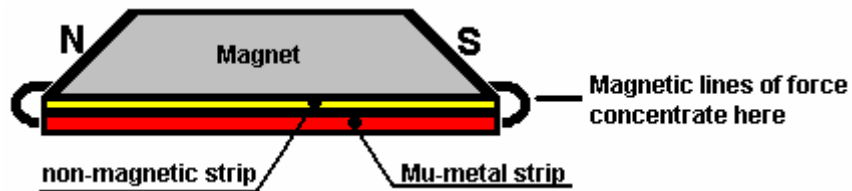

Hans Coler. German naval captain Hans Coler invented an over-unity generator in 1925. He called this device the 'Stromerzeuger' and for a few watts from a dry battery it provided 6 KW continuously. He was refused development support because it was "a perpetual motion machine".

Hans also invented a passive device which he called the '**Magnetstromapparat**'. His unit required very careful and slow adjustment to get it operating but when it started it continued on test in a locked room for three months of continuous operation. Nobody, including Hans, seems any too sure how this device works but it is presented here in case you wish to research it further. It comprises six bar magnets wound as shown here. Some are wound in a clockwise direction when looking at the North pole and these are called "Right" those wound in an anticlockwise direction are called "Left":

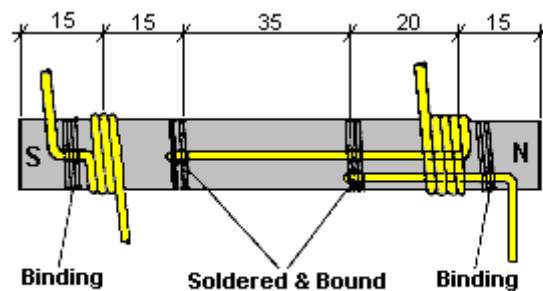

Note: There is paper insulation between magnet and coil

These six magnets are arranged in a hexagon and wired as shown here:

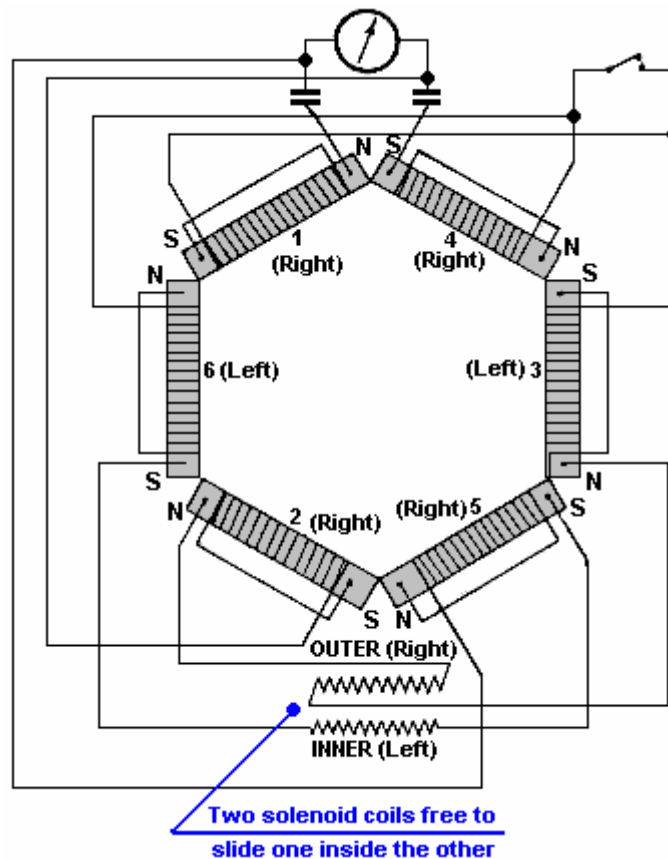

And the schematic diagram is:

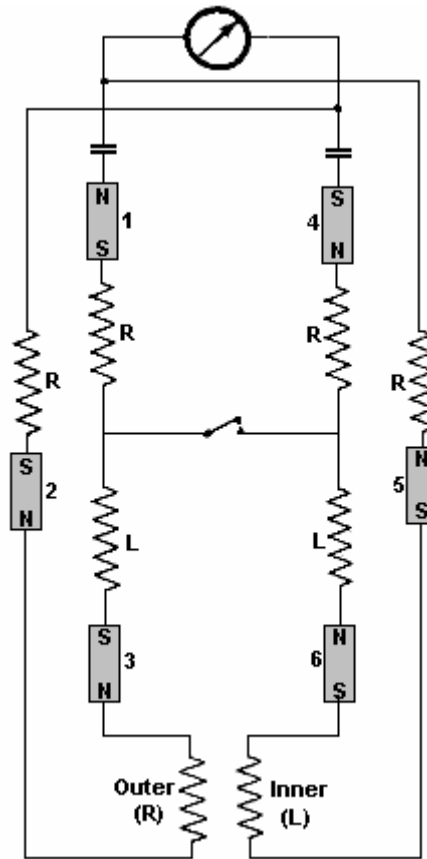

One extremely interesting feature of this passive device is that it has been witnessed producing 450 mV for several hours; it was capable of developing up to 12 Volts. The witnesses were quite sure that it was not picking up radio or mains input. So, what was it picking up?

To operate the device, the switch is left in the open position, the magnets are moved slightly apart and the sliding coil set into various positions with a wait of several minutes between adjustments. The magnets are then separated still further and the coils moved again. This process is repeated until at a critical separation of the magnets, a voltage is developed. The switch is now closed and the process continued more slowly. The voltage then builds up to a maximum which is then maintained indefinitely. The position of the apparatus in the room and the orientation of the device had no effect on the output.

The magnets were selected to be as nearly equal in strength as possible and the resistance of the magnet and coil were checked after winding to make sure they were as nearly equal as possible (about 0.33 ohms).

The “**Stromerzeuger**” consisted of an arrangement of magnets, flat coils and copper plates with a primary circuit powered by a small battery. The output from the secondary circuit was used to light a bank of lamps and it was claimed that the output power was many times the input power and to continue indefinitely.

The apparatus principally consists of two parallel connected spools which being bi-filarly wound in a special way, are magnetically linked together. One of these spools is composed of copper sheets (the spool is called the ‘plate spool’). The other one is made of a number of thin parallel connected isolated wires (called ‘spool winding’), running parallel to the plates, at small intervals. Both spools can be fed by separate batteries (6 Volt, 6.5 Ahr were used). At least two batteries are needed to get the apparatus operating, but subsequently, one battery can be removed.

The spools are arranged in two halves each by the bi-filar windings. The plate spool also contains iron rods with silver wire connections. These rods are magnetised by a special battery through exciter

windings. Electrically, the exciter winding is completely isolated from the other windings. Hans said that the production of energy takes place principally in these iron rods and the winding of the spools plays an essential part in the process.

It should be mentioned that the spool circuit is powered up first. Initially, it took a current of 104 mA. The plates and exciter circuits are then switched on simultaneously. When this is done, the current in the spool circuit dropped from 104 mA to about 27 mA.

It is suggested that an electron be not only regarded as a negatively charged particle but also as a South magnetic pole. The basic Stromerzeuger element is that of an open secondary circuit, capacity loaded, inductively coupled to a primary circuit. The novel feature is that the capacities are connected to the secondary core through permanent magnets as shown here:

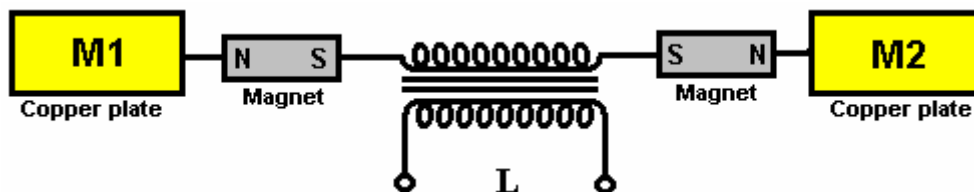

It is claimed that on switching on the primary circuit, “separation of charges” takes place with M1 becoming positively charged and M2 becoming negatively charged and that these charges are “magnetically polarised” when they formed, owing to the presence of the magnets. When the primary circuit is switched off, a “reversing current” flows in the secondary but the magnets “do not exert a polarising effect on this reversal”.

Two of the basic elements shown above are placed together making a double stage arrangement with the copper plates close together (presumably as capacitor plates):

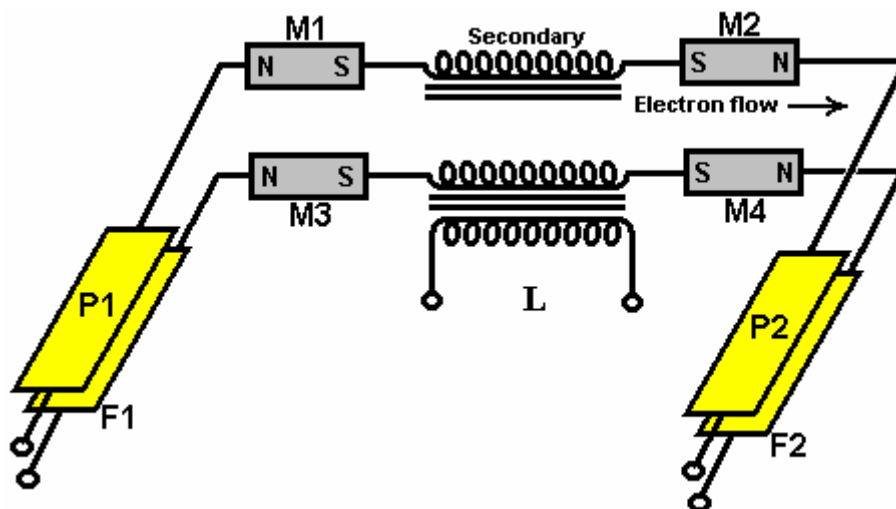

The secondary windings are both exactly equal and wound in a direction such that, on switching the primary coil on, the electrons in the secondary coil flow from P1 to P2 and from F1 to F2. This is the basic working arrangement. More of these double stages can be added to provide higher outputs.

Floyd Sweet. Another device in the same category of permanent magnets with energised coils round it (and very limited practical information available) was produced by Floyd Sweet. The device was dubbed “Vacuum Triode Amplifier” or “VTA” by Tom Bearden and the name has stuck, although it does not appear to be a particularly accurate description.

The device was capable of producing more than 1 kW of output power at 120 Volts, 60 Hz and is self-powered. The output is energy which resembles electricity in that it powers motors, lamps, etc. but as the power increases through any load there is a temperature drop instead of the expected temperature rise.

When it became known that he had produced the device he became the target of serious threats, some of which were delivered face-to-face in broad daylight. It is quite possible that the concern was due to the

device tapping zero-point energy, which when done at high currents opens a whole new can of worms. One of the observed characteristics of the device was that when the current was increased, the measured weight of the apparatus reduced by about a pound. While this is hardly new, it suggests that space/time was being warped. The German scientists at the end of WWII had been experimenting with this (and killing off the unfortunate people who were used to test the system) - if you have considerable perseverance, you can read up on this in Nick Cook's inexpensive book "The Hunt for Zero-Point" ISBN 0099414988.

Floyd found that the weight of his device reduced in proportion to the amount of energy being produced. But he found that if the load was increased enough, a point was suddenly reached where a loud sound like a whirlwind was produced, although there was no movement of the air. The sound was heard by his wife Rose who was in another room of their apartment and by others outside the apartment. Floyd did not increase the load further (which is just as well as he would probably have received a fatal dose of radiation if he had) and did not repeat the test. In my opinion, this is a dangerous device and I personally, would not recommend anyone attempting to build one. It should be noted that a highly lethal 20,000 Volts is used to 'condition' the magnets and the principles of operation are not understood at this time. Also, there is insufficient information to hand to provide realistic advice on practical construction details.

On one occasion, Floyd accidentally short-circuited the output wires. There was a bright flash and the wires became covered with frost. It was noted that when the output load was over 1 kW, the magnets and coils powering the device became colder, reaching a temperature of 20 degrees Fahrenheit below room temperature. On one occasion, Floyd received a shock from the apparatus with the current flowing between the thumb and the small finger of one hand. The result was an injury akin to frostbite, causing him considerable pain for at least two weeks.

Observed characteristics of the device include:

1. The output voltage does not change when the output power is increased from 100W to 1 kW.
2. The device needs a continuous load of at least 25W.
3. The output falls in the early hours of the morning but recovers later on without any intervention.
4. A local earthquake can stop the device operating.
5. The device can be started in self-powered mode by briefly applying 9 Volts to the drive coils.
6. The device can be stopped by momentary interruption of the power to the power coils.
7. Conventional instruments operate normally up to an output of 1 kW but stop working above that output level, with their readings showing zero or some other spurious reading.

Information is limited, but it appears that Floyd's device was comprised of one or two large ferrite permanent magnets (grade 8, size 150 mm x 100 mm x 25 mm) with coils wound in three planes mutually at right angles to each other (i.e. in the x, y and z axes). The magnetisation of the ferrite magnets is modified by suddenly applying 20,000 Volts from a bank of capacitors (510 Joules) or more to plates on each side of it while simultaneously driving a 1 Amp 60 Hz (or 50 Hz) alternating current through the energising coil. The alternating current should be at the frequency required for the output. The voltage pulse to the plates should be applied at the instant when the 'A' coil voltage reaches a peak. This needs to be initiated electronically.

It is said that the powering of the plates causes the magnetic material to resonate for a period of about fifteen minutes, and that the applied voltage in the energising coil modifies the positioning of the newly formed poles of the magnet so that it will in future, resonate at that frequency and voltage. It is important that the voltage applied to the energising coil in this 'conditioning' process be a perfect sinewave. Shock, or outside influence can destroy the 'conditioning' but it can be reinstated by repeating the conditioning process. It should be noted that the conditioning process may not be successful at the first attempt but repeating the process on the same magnet is usually successful. Once conditioning is completed, the capacitors are no longer needed. The device then only needs a few milliwatts of 60 Hz applied to the input coil to give up to 1.5 kW at 60 Hz at the output coil. The output coil can then supply the input coil indefinitely.

The conditioning process modifies the magnetisation of the ferrite slab. Before the process the North pole is on one face of the magnet and the South pole on the opposite face. After conditioning, the South pole does not stop at the mid point but extends to the outer edges of the North pole face, extending inwards from the edge by about 6 mm. Also, there is a magnetic 'bubble' created in the middle of the North pole face and the position of this 'bubble' moves when another magnet is brought near it.

The conditioned slab has three coil windings:

1. The 'A' coil is wound first around the outer perimeter, each turn being $150 + 100 + 150 + 100 = 500$ mm long (plus a small amount caused by the thickness of the coil former material). It has about 600 turns of 28 AWG (0.3 mm) wire.

2. The 'B' coil is wound across the 100 mm faces, so one turn is about $100 + 25 + 100 + 25 = 250$ mm (plus a small amount for the former thickness and clearing coil 'A'). It has between 200 and 500 turns of 20 AWG (1 mm) wire.

3. The 'C' coil is wound along the 150 mm face, so one turn is $150 + 25 + 150 + 25 = 350$ mm (plus the former thickness, plus clearance for coil 'A' and coil 'B'). It has between 200 and 500 turns of 20 AWG (1 mm) wire and should match the resistance of coil 'B' as closely as possible.

Coil 'A' is the input coil. Coil 'B' is the output coil. Coil 'C' is used for the conditioning and for the production of gravitational effects.

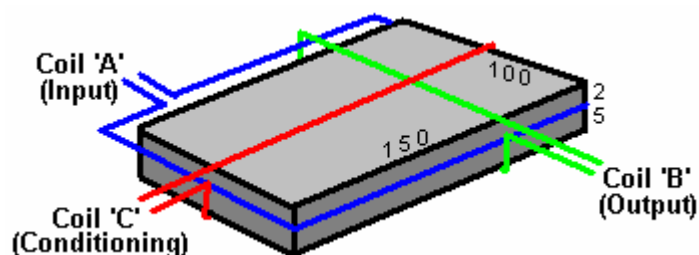

Much of this information and photographs of the original device can be found on the website:

["http://www.intalek.com/Index/Projects/Research/Construction%20of%20the%20Floyd%20Sweet's%20VT A%20by%20Michael%20Watson.htm"](http://www.intalek.com/Index/Projects/Research/Construction%20of%20the%20Floyd%20Sweet's%20VT A%20by%20Michael%20Watson.htm) where a paper by Michael Watson gives much practical information. For example, he states that an experimental set up which he made, had the 'A' coil with a resistance of 70 ohms and an inductance of 63 mH, the 'B' coil, wound with 23 AWG wire with a resistance of 4.95 ohms and an inductance of 1.735 mH, and the 'C' coil, also wound with 23 AWG wire, with a resistance of 5.05 ohms and an inductance of 1.78 mH.

In passing, if the gravity thrust aspect of this information interests you, let me mention a television documentary programme which you may not have seen. In it, Boyd Bushman demonstrated what might just have been a simplistic gravity thrust device. Boyd is a US weapons designer of 35 years experience. He designed the prototype for the 'Stinger' missile. He moved to Lockheed as a designer. There he experimented with various things including the model he demonstrated.

It consisted of 250 turns of 30 AWG enamelled wire wound in a circular bundle about 200 mm in diameter. The winding was circular in cross section and air cored. The turns were secured by masking tape, some of which was used to tether the ring to a table top. He then plugged the coil directly in to the 110V 60 Hz mains supply. The ring immediately lifted off the table.

Boyd described the device as dangerous as it becomes very hot in just a few seconds. He stated that in his opinion, fed with different voltage and frequency, the ring could be made able to provide thrust for a full-scale flying vehicle.

Tom Bearden. Tom Bearden, Stephen Patrick, James Hayes, Kenneth Moore and James Kenny were granted US Patent 6,362,718 on 26th March 2002. This patent is for an electromagnetic generator with no moving parts. This device can be self-powered and is described on JL Naudin's excellent site at <http://jnaudin.free.fr/meg/megv21.htm> where test results are shown. This device has been shown to have a greater output than its input and an output five times higher than the input has been mentioned.

The "Motionless Electromagnetic Generator" or "MEG" consists of a magnetic ring with output coils wound on it. Inside the ring is a permanent magnet to provide a steady magnetic flux around the ring. Superimposed on the ring are two electromagnets which are activated one after the other to make the magnetic flux oscillate. This is very much like Floyd Sweet's "VTA" device.

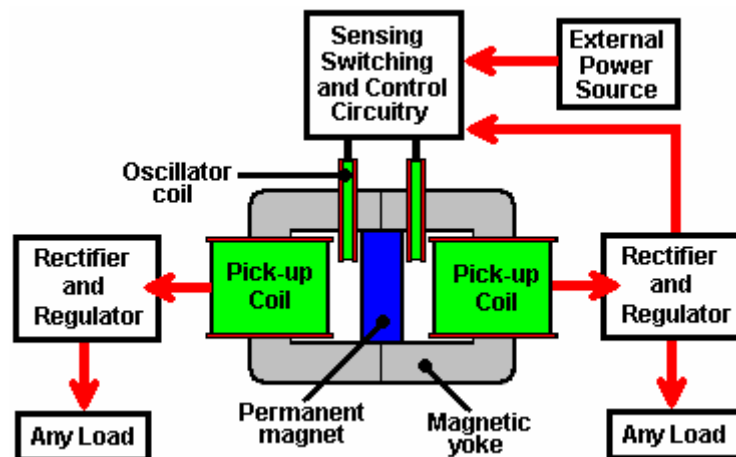

The external power source shown above is intended to be disconnected when the circuit starts operating, at which time, part of the output from one of the pick-up coils is fed back to power the circuit driving the oscillator coils. The circuit then becomes self-sustaining, with no external input but with a continuous electrical output.

If you should construct one of these, please be warned that it should **not** be started up unless there is an external load across the pick-up coils, otherwise dangerous, potentially lethal voltages can be produced. Don't get yourself killed or injured - please be very careful.

A re-worded excerpt from the patent for this system, is in PatD4 of this set of documents and it gives the construction details of the prototype: dimensions, number of turns, materials used, drive frequency, monostable pulse durations, etc. The prototype produced two outputs of 48 watts for one input of 12 watts. This allowed the input power to be taken from one of the outputs, while that same output was powering other loads.

This device is essentially, a custom-built transformer with two primary windings (the oscillator coils) and two secondary windings (the pick-up coils), with a permanent magnet inserted to create a standing magnetic field through the yoke (frame) of the transformer. However, a permanent magnet has two separate energy streams coming from it. The main field is the magnetic field which is very well known. It normally flows out in every direction, but in the MEG, a very good conducting path is provided by the frame of the device. This traps the magnetic energy flow and channels it around inside the frame. This prevents it masking the second energy field which is the Electrical energy field. With the magnetic field moved out of the way, it is now possible to tap this energy field for additional power output.

The MEG looks like a very simple device, but in actual fact, it is not. To act as a successful device with a Coefficient of Performance (COP) over 1, where the input power which is provided is less than the useful power output of the device, then Tom says that the frame needs to be made from a nanocrystalline material. This material has special properties which give the MEG its exceptional output and it is described in Device Patents No 4. in this series of documents.

Care has to be taken with this device as the output power can be so high that it can burn the insulation off the wires and destroy the device if the output power is not controlled carefully. The output power is normally limited to a COP of 5.4 for practical reasons. If the necessary input power is taken from the output power via a rigorous control circuit which prevents runaway, then the device can provide output power while no outside input power is needed.

The output power is controlled by the waveform being sent to the oscillator coils. The power is controlled by the exact shape of the "square wave" drive:

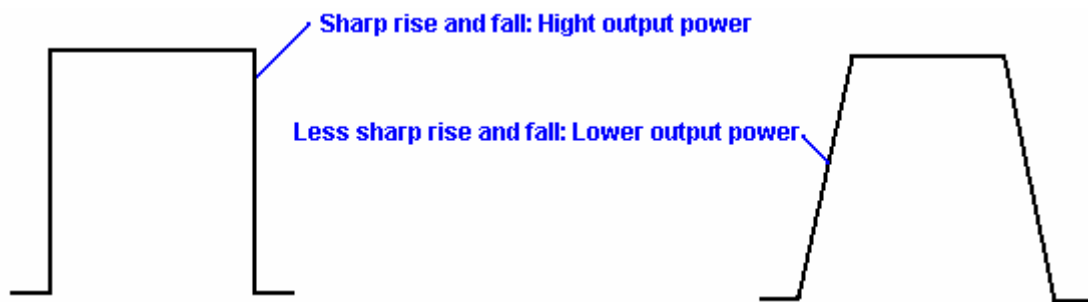

This waveform is adjusted carefully to keep the COP down to 5.4 for safety sake. The waveform is also adjustable for frequency and Mark/Space ratio.

As it is some years since this device was patented, the question can be asked as to why it is not in production and offered for sale everywhere. The reason is that the MEG is a laboratory prototype which needs careful adjustment and tweaking. It has been replicated by others and its performance verified as being $COP > 1$, but it is not yet ready for production where it is necessary to have the design enhanced to the stage that it can be assembled in a factory and work immediately without the need for manual adjustments. That development is in hand and may be completed in the next year or two.

Some further explanation is in order. The MEG has an overall efficiency, well below 100% in spite of having a Coefficient Of Performance well in excess of 1. The COP of 5.4 mentioned earlier is an arbitrary figure selected by the designers to prevent the insulation being burnt off the output wires. The actual maximum output is almost unlimited, certainly a COP of 100 is perfectly possible, but quite unnecessary in practical terms.

If a standard laminated iron yoke is used for the MEG, it will never have a $COP > 1$ as input power will be needed to make it operate. The magnetic flux from a permanent magnet consists of two components. One component is rotary and it spreads out in every direction. The second component is linear and it gets swamped and hidden by the rotary field. If a torroidal yoke wound with an input winding over its whole length is used, then that traps all of the rotating magnetic field inside the torroid. The snag is that this requires considerable input power to energise the torroidal winding. The big advance with the MEG is that the inventors have discovered some standard off-the-shelf nanocrystalline materials which have the property of trapping the rotational magnetic field inside a torroid formed from them, **without** the need for any energising coil. This is a major boost to the functioning of the device.

Now, with the rotational magnetic field trapped inside the torroid, the linear field becomes accessible, and it is a very useful field indeed. It is electrical in nature. In actual fact, magnetism and electricity are not two separate things, but instead, they are different aspects of the same thing, so both should really be referred to as "electromagnetism". Anyway, the linear field is easy to access once the rotational field has been removed. All that is necessary is to pulse it sharply. When that is done, real electricity is introduced into the MEG from the surrounding environment. The sharper the waveform, the greater the additional electrical input becomes. This is what makes the MEG have a COP of say, 5.4 which is a practical working output. If the output is then manipulated to provide the input power needed for the pulsing, the COP effectively becomes infinite as you do not have to provide any power to make it work and you have a substantial power output. The power output divided by the power input you have to provide to make the device operate, gives the COP rating, so any output divided by zero input, always gives infinity.

Dave Lawton has experimented with the MEG arrangement, using a professionally constructed custom laminated iron yoke. He found that using the standard arrangement, he found no difference when he removed the permanent magnet. Testing various configurations, he found that the most effective set-up for his components is:

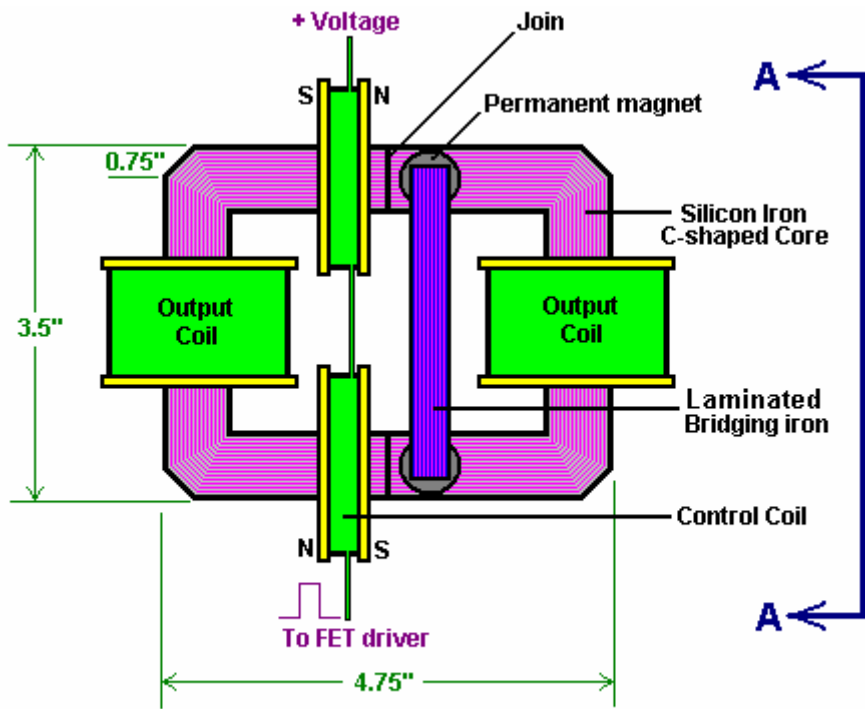

SIDE VIEW

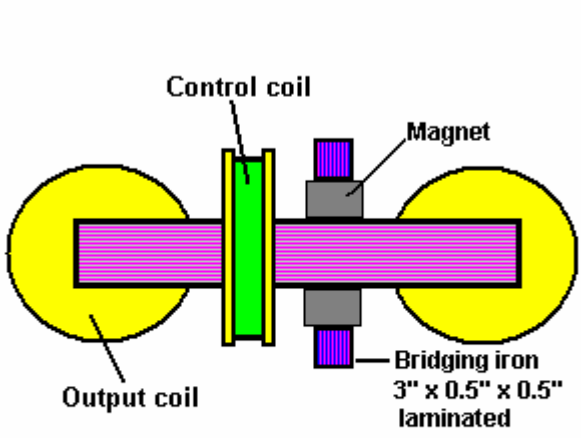

TOP VIEW

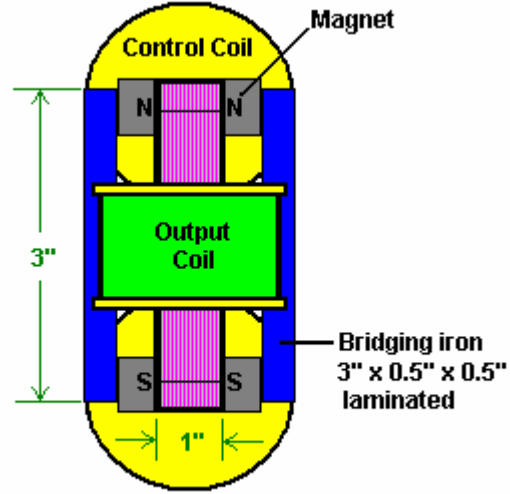

SECTION A-A

Here, the drive coils are both put asymmetrically on one side of the frame and wired so that their pulses complement each other. Then two pairs of button magnets are placed on the other side of the centreline, each side of the yoke, and bridged together with two straight vertical sections of laminated iron bar. This arrangement is sensitive to the exact position of these magnets and tuning is achieved by moving the group of four magnets and two bars (effectively two "horseshoe" magnets) slightly left or right to find the optimum position. Introducing or removing these magnets then made a considerable difference to the operation of the device.

There are other devices which are very close to the MEG construction. One of these is at present being displayed on the web page <http://www.inkomp-delta.com/page8.html>, though for full understanding of what is being said, considerable language skills are needed as the translation programs fail dramatically when asked to translate this information. However, the following information appears to be displayed there by Elin Pelin and Valeri Ivanov and dated 11th February 2007:

An effective device can be constructed from a permanent magnet, a toroid and a laminated iron yoke. The arrangement is displayed like this:

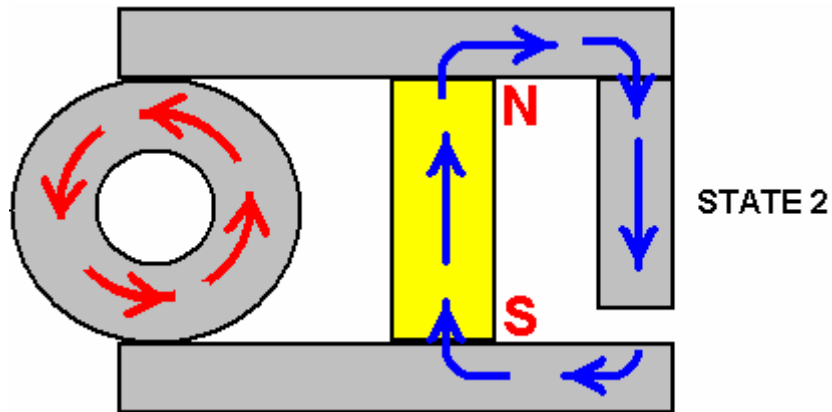
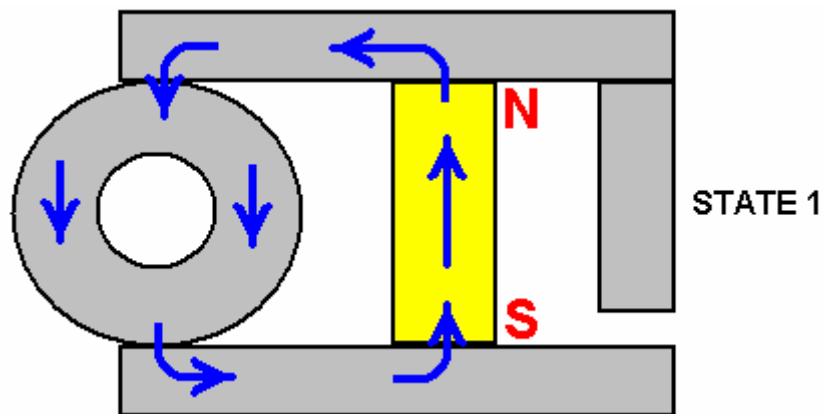

It appears that when the switch is made from State 1 to State 2, that a rotating magnetic field is set up in the toroid. Presumably, the switching will be caused by pulsing a coil wound around the yoke and the output power pick-up from a coil around the toroid like this:

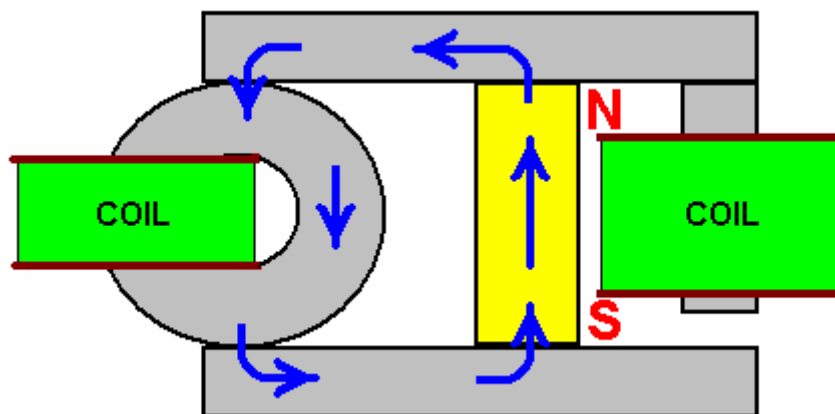

If you are fluent in Russian (or whatever language is used on the web site) it would be most helpful if you would let me know if this description is accurate, and if there are any important additional details which need to be stressed, or any experimental results which it would be useful to know about.

The Phi-Transformer. Toroidal shapes are clearly important in many devices which pull in additional energy from the environment, even to the extent that Bob Boyce warns against the high-frequency sequential pulsing of coils wound on a toroid yoke, producing a rotating magnetic field as unpredictable surge events can generate some 10,000 amps of additional current which will burn out the circuit components and can very well trigger a radiant energy build up which can create a lightning strike. Bob himself has been hit by just such a lightning strike and he is lucky to have survived. Lesser systems such as the toroid transformer used in Bob's electrolyser system are safe even though they generate a power gain. So the many toroidal system designs are definitely worth examining.

One of these is the "Phi-Transformer" which looks like a somewhat similar arrangement to the MEG described above. However, it operates in quite a different way:

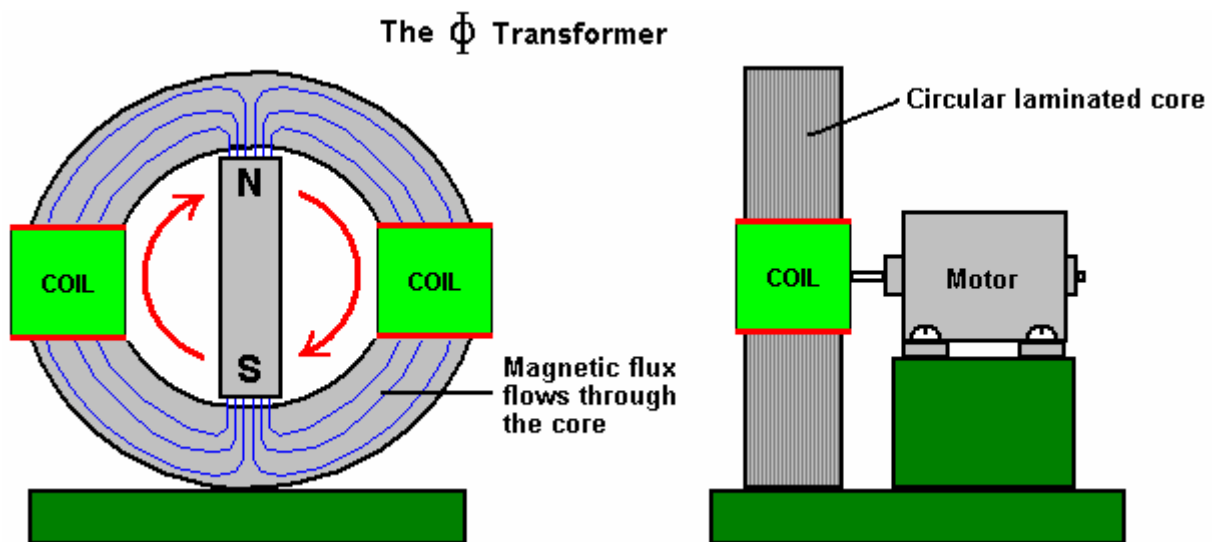

Here, lines of magnetic flux coming from a permanent magnet are channelled through a laminated yoke which is effectively a circular mains transformer core. The difference is in the fact that instead of electronically driving a coil to alter the flux coming from the permanent magnet, in this system the magnet is rotated by a small motor.

The performance of this device is impressive. The power required to rotate the magnet is not unduly affected by the current drawn from the coils. The flux is channelled through the laminated iron core and in tests an output of 1200 watts for an input of 140 watts has been achieved, and that is a COP of 8.5 which is very respectable, especially for such a simple device.

The Dave Squires Generator. At <http://jnaudin.free.fr/html/dsqromg2.htm> a generator design is shown, dated 1999. All attempts to contact Dave Squires have been unsuccessful, so it is not known if the information there is from tests on a device which has actually been built or if it is just a theoretical design, though it is likely that it was not built at that time. The design is almost identical to the Phi Transformer. A central core is produced by casting the shape shown below, using an amorphous iron powder / epoxy mix. However, as the operating frequency is low at only 50 Hz or 60 Hz, there does not seem to be any reason why normal transformer laminations should not be used, in which case six sets of shims shaped like this:



which would make the winding of the coils very much easier as standard bobbins could be slotted into place as the core yoke is being assembled.

However, the complete core is shaped like this with coils placed in the slots:

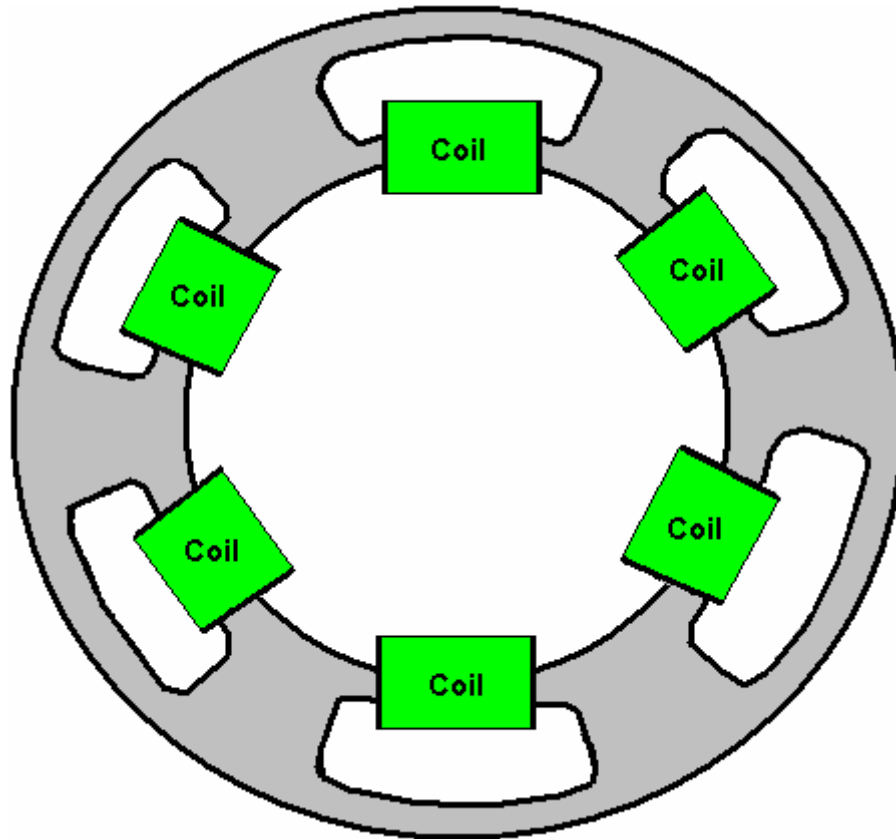

The thinking behind this arrangement is that the "back-EMF" magnetic flux which normally causes Lenz Law opposition to the free rotation of the magnets around the toroid, is diverted around behind the coil and turned so that instead of hindering the rotation, it actually assists it:

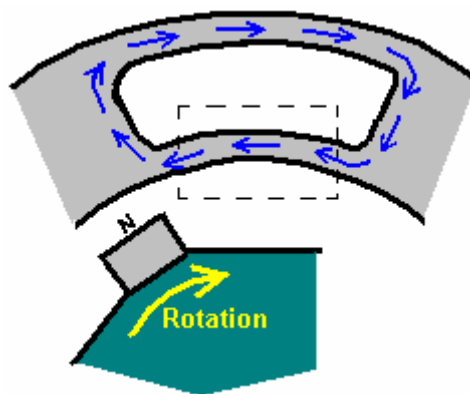

The speed of rotation is quoted as being 1,000 rpm for 50 Hz and 1,200 rpm for 60 Hz, which appears incorrect to me, there being six pulses per rotation, so 500 rpm and 600 rpm would appear the actual rates of rotation required. The coil windings are suggested as being 180 turns of AWG 14 (16 SWG) for 120 volts AC, at a supposed current of 100 amps, which is quite unrealistic as the maximum current for that size of wire is 5.9 amps. The magnets are 2 inches long, 1 inch deep neodymium set into a circular rotor of 12 inch diameter. There can, of course, be more than one rotor on a single shaft, and the number of turns would be doubled for 240 volts AC output.

The yoke on which the coils are wound is effectively a series of toroids, though admittedly, not exactly circular in shape. An alternative shape which might be considered would be as shown below where the section carrying the magnetic flux for any one coil is more isolated from the other toroids. It is not clear if making the section which passes through the coil, straight rather than curved, so I will leave that detail to people who are expert in magnetics.

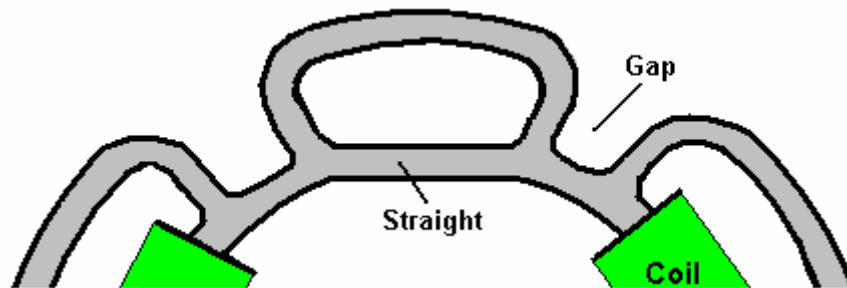

Dan Davidson. Dan has produced a system rather similar to the 'MEG' described above. His system is different in that he uses an acoustic device to vibrate a magnet which forms the core of a transformer. This is said to increase the output by a substantial amount. His arrangement looks like this:

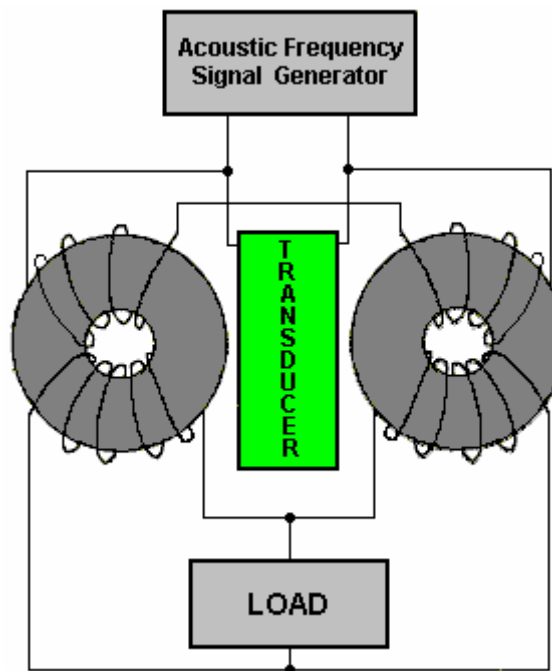

Dan's patent forms part of this set of documents and it gives details of the types of acoustic transducers which are suitable for this generator design.

Pavel Imris. Pavel was awarded a US patent in the 1970's. The patent is most interesting in that it describes a device which can have an output power which is more than nine times greater than the input power. He achieves this with a device which has two pointed electrodes enclosed in a quartz glass envelope which contains xenon gas under pressure (the higher the pressure, the greater the gain of the device) and a dielectric material.

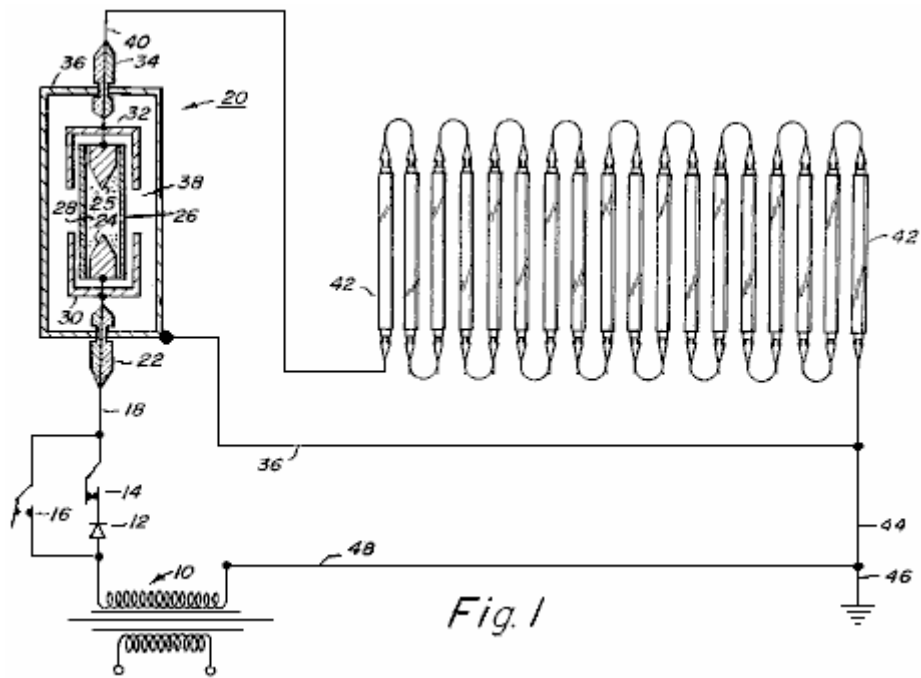

Fig. 1

Here, the power supply to one or more standard fluorescent lamps is passed through the device. This produces a power gain which can be spectacular when the gas pressure in the area marked '24' and '25' in the above diagram is high. The patent is included in this set of documents and it contains the following table of experimental measurements:

Table 1 shows the data to be obtained relating to the optical electrostatic generator. **Table 2** shows the lamp performance and efficiency for each of the tests shown in **Table 1**. The following is a description of the data in each of the columns of **Tables 1 and 2**.

Column	Description
B	Gas used in discharge tube
C	Gas pressure in tube (in torrs)
D	Field strength across the tube (measured in volts per cm. of length between the electrodes)
E	Current density (measured in microamps per sq. mm. of tube cross-sectional area)
F	Current (measured in amps)
G	Power across the tube (calculated in watts per cm. of length between the electrodes)
H	Voltage per lamp (measured in volts)
K	Current (measured in amps)
L	Resistance (calculated in ohms)
M	Input power per lamp (calculated in watts)
N	Light output (measured in lumens)

Table 1

	Optical		Generator	Section		
A	B	C	D	E	F	G
Test No.	Type of discharge	Pressure of Xenon	Field strength	Current density	Current	Power str. across lamp

	lamp		across lamp			
		(Torr)	(V/cm)	(A/sq.mm)	(A)	(W/cm.)
1	Mo elec	-	-	-	-	-
2	Xe	0.01	11.8	353	0.1818	2.14
3	Xe	0.10	19.6	353	0.1818	3.57
4	Xe	1.00	31.4	353	0.1818	5.72
5	Xe	10.00	47.2	353	0.1818	8.58
6	Xe	20.00	55.1	353	0.1818	10.02
7	Xe	30.00	62.9	353	0.1818	11.45
8	Xe	40.00	66.9	353	0.1818	12.16
9	Xe	60.00	70.8	353	0.1818	12.88
10	Xe	80.00	76.7	353	0.1818	13.95
11	Xe	100.00	78.7	353	0.1818	14.31
12	Xe	200.00	90.5	353	0.1818	16.46
13	Xe	300.00	100.4	353	0.1818	18.25
14	Xe	400.00	106.3	353	0.1818	19.32
15	Xe	500.00	110.2	353	0.1818	20.04
16	Xe	600.00	118.1	353	0.1818	21.47
17	Xe	700.00	120.0	353	0.1818	21.83
18	Xe	800.00	122.8	353	0.1818	22.33
19	Xe	900.00	125.9	353	0.1818	22.90
20	Xe	1,000.00	127.9	353	0.1818	23.26
21	Xe	2,000.00	149.6	353	0.1818	27.19
22	Xe	3,000.00	161.4	353	0.1818	29.35
23	Xe	4,000.00	173.2	353	0.1818	31.49
24	Xe	5,000.00	179.1	353	0.1818	32.56

Table 2

		Fluorescent		Lamp	Section	
A	H	K	L	M	N	
Test No.	Voltage	Current	Resistance	Input Energy	Light Output	
	(Volts)	(Amps)	(Ohms)	(Watts)	(Lumen)	
1	220	0.1818	1,210	40.00	3,200	
2	218	0.1818	1,199	39.63	3,200	
3	215	0.1818	1,182	39.08	3,200	
4	210	0.1818	1,155	38.17	3,200	
5	200	0.1818	1,100	36.36	3,200	
6	195	0.1818	1,072	35.45	3,200	
7	190	0.1818	1,045	34.54	3,200	
8	182	0.1818	1,001	33.08	3,200	
9	175	0.1818	962	31.81	3,200	
10	162	0.1818	891	29.45	3,200	
11	155	0.1818	852	28.17	3,200	
12	130	0.1818	715	23.63	3,200	
13	112	0.1818	616	20.36	3,200	
14	100	0.1818	550	18.18	3,200	
15	85	0.1818	467	15.45	3,200	
16	75	0.1818	412	13.63	3,200	
17	67	0.1818	368	12.18	3,200	
18	60	0.1818	330	10.90	3,200	
19	53	0.1818	291	9.63	3,200	
20	50	0.1818	275	9.09	3,200	
21	23	0.1818	126	4.18	3,200	
22	13	0.1818	71	2.35	3,200	
23	8	0.1818	44	1.45	3,200	
24	5	0.1818	27	0.90	3,200	

The results from Test No. 24 where the gas pressure is a very high 5,000 Torr, show that the input power for each 40-watt standard fluorescent tubes is 0.9 watts for full lamp output. In other words, each lamp is working to its full specification on less than one fortieth of its rated input power. However, the power taken by the device in that test was 333.4 watts which with the 90 watts needed to run the 100 lamps, gives a total input electrical power of 423.4 watts instead of the 4,000 watts which would have been needed without the device. That is an output power of more than nine times the input power.

From the point of view of any individual lamp, without using this device, it requires 40 watts of electrical input power to give 8.8 watts of light output which is an efficiency of about 22% (the rest of the input power being converted to heat). In test 24, the input power per lamp is 0.9 watts for the 8.8 watts of light produced, which is a lamp efficiency of more than 900%. The lamp used to need 40 watts of input power to perform correctly. With this device in the circuit, each lamp only needs 0.9 watts of input power which is only 2.25% of the original power. Quite an impressive performance for so simple a device!

Graham Gunderson

On 27th July 2006, a patent application from Graham Gunderson for a **Solid State Electric Generator** was published (number US 2006/0163971 A1). The details are as follows:

Abstract

A solid-state electrical generator including at least one permanent magnet, magnetically coupled to a ferromagnetic core provided with at least one hole penetrating its volume; the hole(s) and magnet(s) being placed so that the hole(s) intercept flux from the permanent magnet(s) coupled into the ferromagnetic core. A first wire coil is wound around the ferromagnetic core for the purpose of moving the coupled permanent magnet flux within the ferromagnetic core. A second wire is routed through the hole(s) penetrating the volume of the ferromagnetic core, for the purpose of intercepting this moving magnetic flux, thereby inducing an output electromotive force. A changing voltage applied to the first wire coil causes coupled permanent magnet flux to move within the core relative to the hole(s) penetrating the core

volume, thus inducing electromotive force along wire(s) passing through the hole(s) in the ferromagnetic core. The mechanical action of an electrical generator is therefore synthesised without the use of moving parts.

Background

This invention relates to a method and device for generating electrical power using solid state means.

It has long been known that moving a magnetic field across a wire will generate an electromotive force (EMF), or voltage, along the wire. When this wire is connected in a closed electrical circuit, an electric current, capable of performing work, is driven through this closed circuit by the induced electromotive force.

It has also long been known that this resulting electric current causes the closed circuit to become encircled with a secondary, induced magnetic field, whose polarity opposes the primary magnetic field which first induced the EMF. This magnetic opposition creates mutual repulsion as a moving magnet approaches such a closed circuit, and a mutual attraction as that moving magnet moves away from the closed circuit. Both these actions tend to slow or cause "drag" on the progress of the moving magnet, causing the electric generator to act as a magnetic brake, whose effect is in direct proportion to the amount of electric current produced.

Historically, gas engines, hydroelectric dams and steam-fed turbines have been used to overcome this magnetic braking action which occurs within mechanical generators. A large amount of mechanical power is required to produce a large amount of electrical power, since the magnetic braking is generally proportional to the amount of electrical power being generated.

There has long been felt the need for a generator which reduces or eliminates the well-known magnetic braking interaction, while nevertheless generating useful electric power. The need for convenient, economical and powerful sources of renewable energy remains urgent. When the magnetic fields within a generator are caused to move and interact by means other than applied mechanical force, electric power can be supplied without the necessity of consuming limited natural resources, thus with far greater economy.

Summary of the Invention

It has long been known that the source of the magnetism within a permanent magnet is a spinning electric current within ferromagnetic atoms of certain elements, persisting indefinitely in accord with well-defined quantum rules. This atomic current encircles every atom, thereby causing each atom to emit a magnetic field, as a miniature electromagnet.

This atomic current does not exist in magnets alone. It also exists in ordinary metallic iron, and in any element or metallic alloy which can be "magnetised", that is, any material which exhibits ferromagnetism. All ferromagnetic atoms and "magnetic metals" contain such quantum atomic electromagnets.

In specific ferromagnetic materials, the orientation axis of each atomic electromagnet is flexible. The orientation of magnetic flux both internal and external to the material, pivots easily. Such materials are referred to as magnetically "soft", due to this magnetic flexibility.

Permanent magnet materials are magnetically "hard". The orientation axis of each is fixed in place within a rigid crystal structure. The total magnetic field produced by these atoms cannot easily move. This constraint aligns the field of ordinary magnets permanently, hence the name "permanent".

The axis of circular current flow in one ferromagnetic atom can direct the axis of magnetism within another ferromagnetic atom, through a process known as "spin exchange". This gives a soft magnetic material, like raw iron, the useful ability to aim, focus and redirect the magnetic field emitted from a magnetically hard permanent magnet.

In the present invention, a permanent magnet's rigid field is sent into a magnetically flexible "soft" magnetic material. The permanent magnet's apparent location, observed from points within the magnetically soft material, will effectively move, vibrate, and appear to shift position when the magnetisation of the soft magnetic material is modulated by ancillary means (much like the sun, viewed while underwater, appears to move when the water is agitated). By this mechanism, the motion required for generation of electricity can be synthesised within a soft magnetic material, without requiring physical movement or an applied mechanical force.

The present invention synthesises the virtual motion of magnets and their magnetic fields, without the need for mechanical action or moving parts, to produce the electrical generator described here. The present invention describes an electrical generator where magnetic braking known as expressions of Lenz's Law, do not oppose the means by which the magnetic field energy is caused to move. The synthesised magnetic motion is produced without either mechanical or electrical resistance. This synthesised magnetic motion is aided by forces generated in accordance with Lenz's Law, in order to produce acceleration of the synthesised magnetic motion, instead of physical "magnetic braking" common to mechanically-actuated electrical generators. Because of this novel magnetic interaction, the solid-state static generator of the present invention is a robust generator, requiring only a small electric force of operate.

Brief Description of the Drawings

The appended drawings illustrate only typical embodiments of this invention and are therefore not to be considered limiting of its scope, as the invention encompasses other equally effective embodiments.

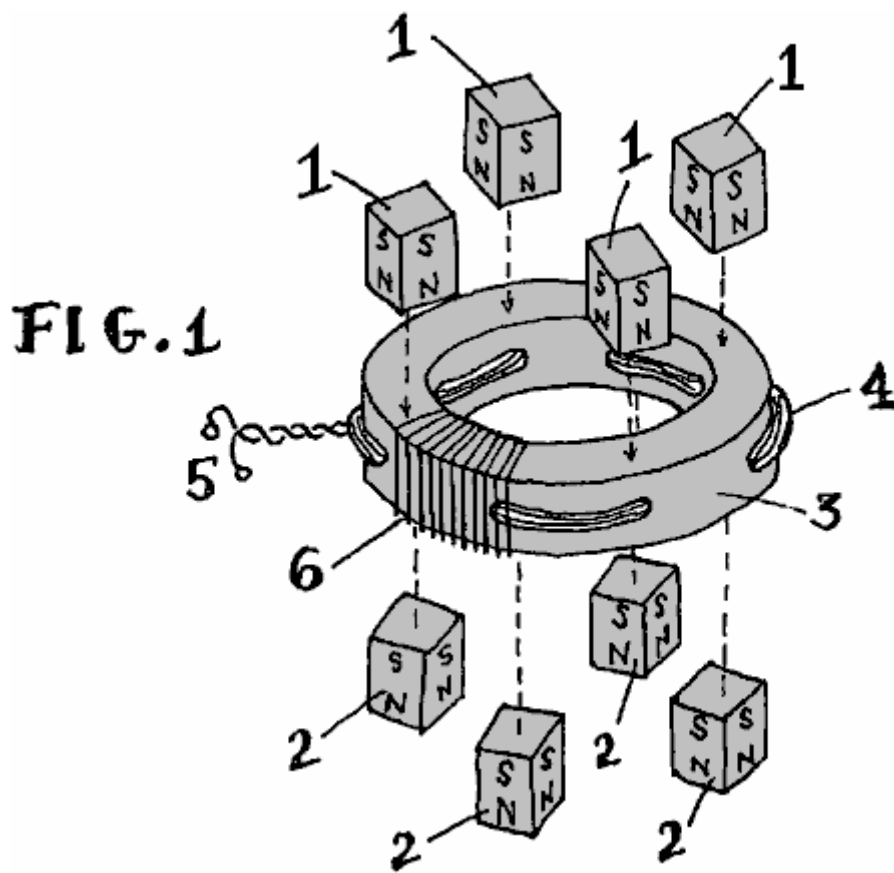

Fig.1 is an exploded view of the generator of this invention.

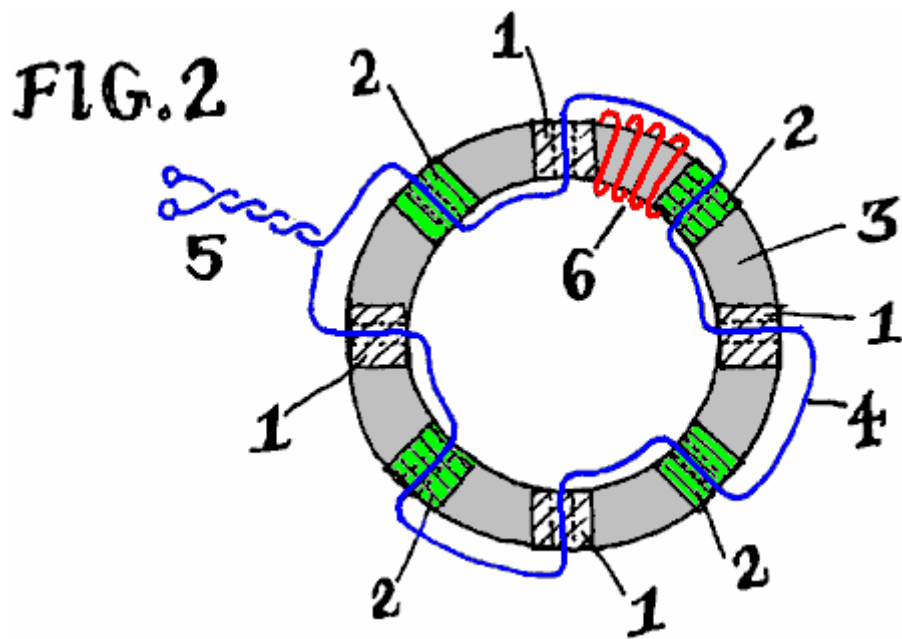

Fig.2 is a cross-sectional elevation of the generator of this invention.

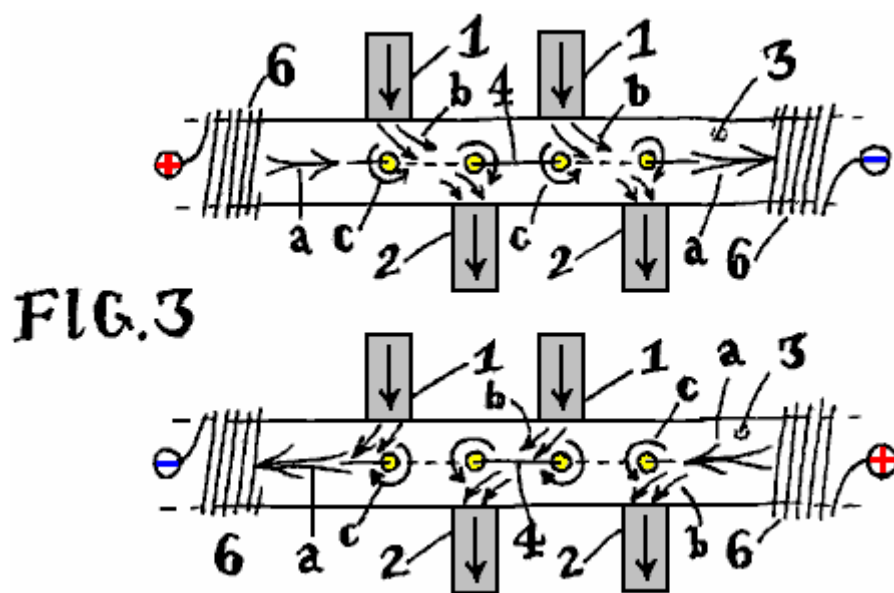

Fig.3 is a schematic diagram of the magnetic action occurring within the generator of Fig.1 and Fig.2.

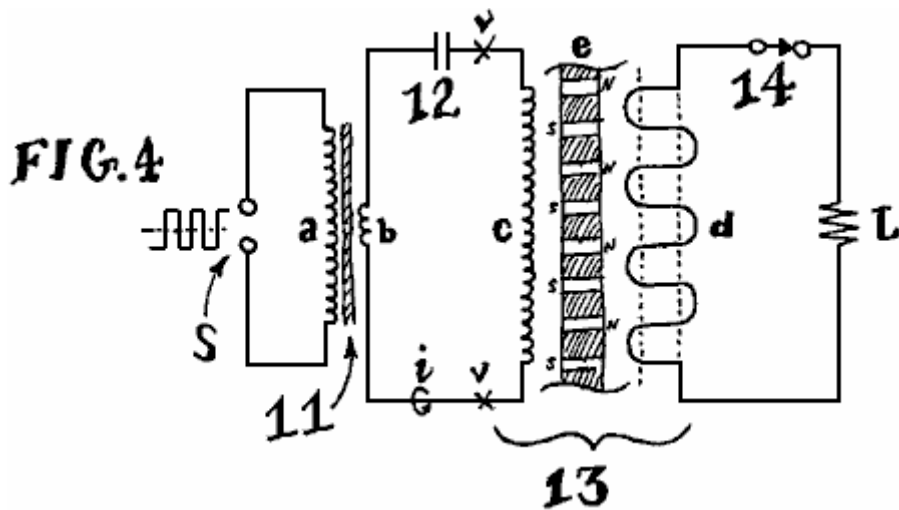
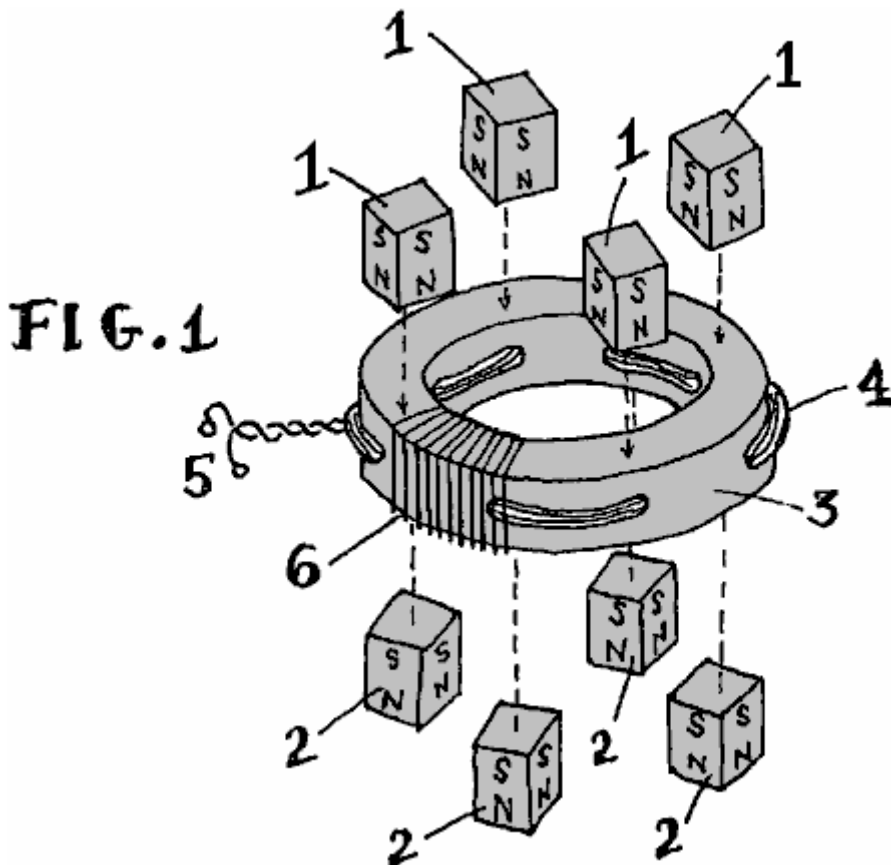

Fig.4 is a circuit diagram, illustrating one method of operating the electrical generator of this invention.

Detailed Description of the Invention

Fig.1 depicts a partially exploded view of an embodiment of an electrical generator of this invention. The part numbers also apply in Fig.2 and Fig.3.



Numeral 1 represents a permanent magnet with its North pole pointing inward towards the soft ferromagnetic core of the device. Similarly, numeral 2 indicates permanent magnets (preferably of the same size, shape and composition), with their South poles aimed inward towards the opposite side, or opposite surface of the device. The letters "S" and "N" denote these magnetic poles in the drawings. Other magnetic polarities and configurations may be used with success; the pattern shown merely illustrates one efficient method of adding magnets to the core.

The magnets may be formed of any polarised magnetic material. In order of descending effectiveness, the most desirable permanent magnet materials are Neodymium-Iron-Boron ("NIB"), Samarium Cobalt, AlNiCo alloy, or "ceramic" Strontium-Barium or Lead-Ferrite. A primary factor determining permanent magnet material composition is the magnetic flux strength of the particular material type. In an embodiment of the invention, these magnets may also be substituted with one or more electromagnets producing the required magnetic flux. In another embodiment of the invention, a superimposed DC current bias can be applied to the output wire to generate the required magnetic flux, replacing or augmenting the permanent magnets.

Numeral **3** indicates the magnetic core. This core is a critical component of the generator. The core determines the output power capacity, the optimum magnet type, the electrical impedance and the operating frequency range. the core may be any shape, composed of any ferromagnetic material, formed by any process (sintering, casting, adhesive bonding, tape-winding, etc.). A wide range of shapes, materials and processes is known in the art of making magnetic cores. Effective common materials include amorphous metal alloys (such as sold under the "Metglas" trademark by Metglas Inc., Conway, S.C.), nanocrystalline alloys, manganese and zinc ferrites as well as ferrites of any suitable element including any combination of magnetically "hard" and "soft" ferrites, powdered metals and ferromagnetic alloys, laminations of cobalt and/or iron and silicon-iron "electrical steel". This invention successfully utilises any ferromagnetic material, while functioning as claimed. In an embodiment of the invention, and for the purpose of illustration, a circular "toroid" core is illustrated. In an embodiment of the invention, the composition may be bonded iron powder, commonly available from many manufacturers.

regardless of core type, the core is prepared with holes, through which, wires may pass. the holes are drilled or formed to penetrate the core's ferromagnetic volume. The toroidal core **3** shown, includes radial holes pointing towards a common centre. If, for example, stiff wire rods were to be inserted through each of these holes, these rods would meet at the centre point of the core, producing an appearance similar to a spoked wheel. If a square or rectangular core (not illustrated) is used, then these holes are preferably oriented parallel to the core's flat sides, causing stiff rods passed through the holes to form a square grid pattern, as the rods cross each other in the interior "window" area framed by the core. While in other embodiments of the invention, these holes may take any possible orientation or patterns of orientation, a simple row of radial holes is illustrated as one example.

Numeral **4** depicts a wire, or bundle of wires which pick up and carry the output power of the generator. Typically, this wire is composed of insulated copper, though other materials such as aluminium, iron, dielectric material, polymers and semiconducting materials may be substituted. It may be seen in **Fig.1** and **Fig.2**, that wire **4** passes alternately through neighbouring holes formed in core **3**. The path taken by wire **4** undulates as it passes in opposite direction through each adjacent hole. If an even number of holes is used, the wire will emerge on the same side of the core on which it first entered. Once all the holes are filled, the resulting pair of trailing leads may be twisted together or similarly terminated, forming the output terminals of the generator shown at numeral **5**. Output wire **4**, may also make multiple passes through each hole in the core. though the winding pattern is not necessarily undulatory, this basic form is shown as an example. Many effective connection styles exist. This illustration shows the most simple.

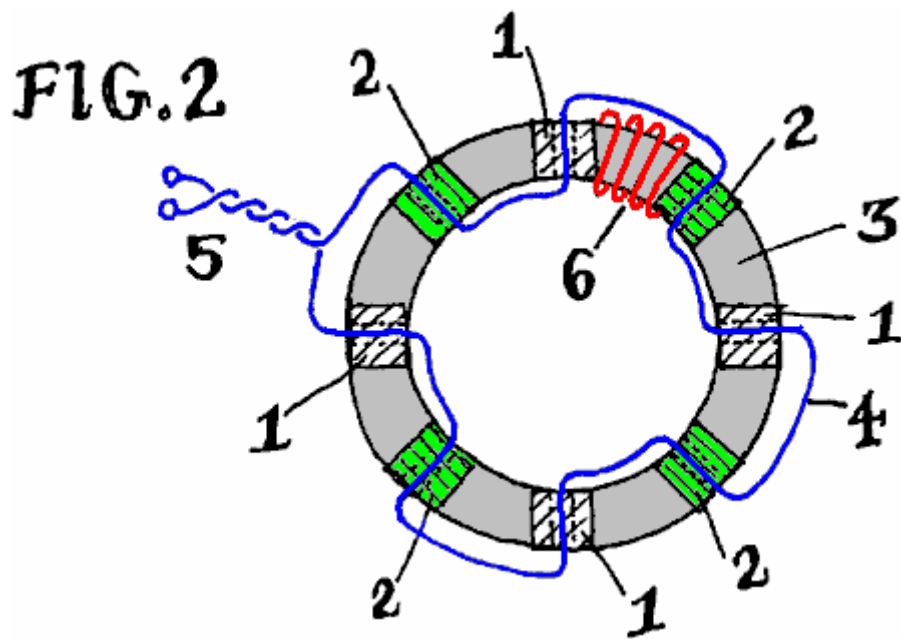

Numeral 6 in Fig.1, Fig.2 and Fig.3, points to a partial illustration of the input winding, or inductive coil used to shift the fields of the permanent magnets, within the core. Typically, this wire coil encircles the core, wrapping around it. For the toroidal core shown, input coil 6 resembles the outer windings of a typical toroidal inductor - a common electrical component. For the sake of clarity, only a few turns of coil 6 are shown in each of Fig.1, Fig.2 and Fig.3. In practice, this coil may cover the entire core, or specific sections of the core, including, or not including the magnets.

Fig.2 shows the same electrical generator of Fig.1, looking transparently "down" through it from above, so that the relative positions of the core holes (shown as dotted lines), the path of the output wire 4, and the position of the magnets (white hatched areas for magnets under the core and green hatched areas for magnets above the core) are made clear. The few representative turns of the input coil 6 are shown in red in Fig.2.

The generator illustrated, uses a core with 8 radially drilled holes. The spacing between these holes is equal. As shown, each hole is displaced by 45 degrees from each of its adjoining holes. The centres of all of the holes lie on a common plane lying half-way down the vertical thickness of the core. Cores of any shape or size may have as few as two or as many as hundreds of holes and a similar number of magnets. Other variations exist, such as generators with multiple rows of holes, zigzag and diagonal patterns, or output wire 4 moulded directly into the core material. In any case, the basic magnetic interaction shown in Fig.3 occurs for each hole in the core as described below.

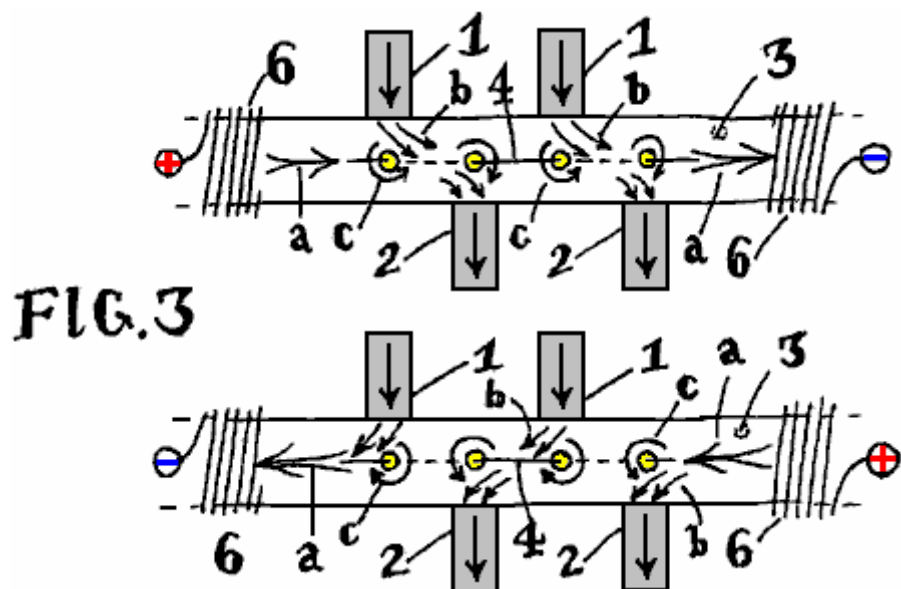

Fig.3 shows the same design, viewed from the side. The curvature of the core is shown flattened on the page for the purpose of illustration. The magnets are represented schematically, protruding from the top and bottom of the core, and including arrows indicating the direction of magnetic flux (the arrow heads point to the magnet's North pole).

In practice, the free, unattached polar ends of the generator's magnets may be left "as-is" in open air, or they may be provided with a common ferromagnetic path linking the unattached North and South poles together as a magnetic "ground". The common return path is typically made of steel, iron or similar material, taking the form of a ferrous enclosure housing the device. It may serve the additional purpose of a protecting chassis. The magnetic return may also be another ferromagnetic core of a similar electric generator stacked on top of the illustrated generator. There can be a stack of generators, sharing common magnets between the generator cores. Any such additions are without direct bearing on the functional principle of the generator itself, and have therefore been omitted from these illustrations.

Two example flux diagrams are shown in **Fig.3**. Each example is shown in a space between schematically depicted partial input coils **6**. A positive or negative polarity marker indicates the direction of input current, applied through the input coil. This applied current produces "modulating" magnetic flux, which is used to synthesise apparent motion of the permanent magnets, and is shown as a double-tailed horizontal arrow (**a**) along the core **3**. Each example shows this double-tailed arrow (**a**) pointing to the right or to the left, depending on the polarity of the applied current.

In either case, vertical flux entering the core (**b,3**) from the external permanent magnets (**1,2**) is swept along within the core, in the direction of the double-tailed arrow (**a**), representing the magnetic flux of the input coil. These curved arrows (**b**) in the space between the magnets and the holes, can be seen to shift or bend (**a --> b**), as if they were streams or jets of air subject to a changing wind.

The resulting sweeping motion of the fields of the permanent magnets, causes their flux (**b**) to brush back and forth over the holes and wire **4** which passes through these holes. Just as in a mechanical generator, when the magnetic flux brushes or "cuts" sideways across a conductor in this way, voltage is induced in the conductor. If an electrical load is connected across the ends of this wire conductor (numeral **5** in **Fig.1** and **Fig.2**), a current flows through the load via this closed circuit, delivering electrical power able to perform work. Input of an alternating current across the input coil **6**, generates an alternating magnetic field (**a**) causing the fields of permanent magnets **1** and **2** to shift (**b**) within the core **3**, inducing electrical power through a load (attached to terminals **5**), as if the fixed magnets (**1,2**) themselves were physically moving. However, no mechanical motion is present.

In a mechanical generator, induced current powering an electrical load, returns through output wire **4**, creating a secondary induced magnetic field, exerting forces which substantially oppose the original magnetic field inducing the original EMF. Since load currents induce their own, secondary magnetic fields opposing the original act of induction in this way, the source of the original induction requires additional energy to restore itself and continue generating electricity. In mechanical generators, the energy-inducing motion of the generator's magnetic fields is being physically actuated, requiring a strong prime mover (such as a steam turbine) to restore the EMF-generating magnetic fields' motion against the braking effect of the output-induced magnetic fields (the induced field **c** and the inducing field **b**), destructively in mutual opposition, which must ultimately be overcome by physical force, which is commonly produced by the consumption of other energy resources.

The electrical generator of the present invention is not actuated by mechanical force. It makes use of the induced secondary magnetic field in such a way as to not cause opposition, but instead, addition and resulting acceleration of magnetic field motion. Because the present invention is not mechanically actuated, and because the magnetic fields do not act to destroy one another in mutual opposition, the present invention does not require the consumption of natural resources in order to generate electricity.

The present generator's induced magnetic field, resulting from electrical current flowing through the load and returning through output wire **4**, is that of a closed loop encircling each hole in the core. The induced magnetic fields create magnetic flux in the form of closed loops within the ferromagnetic core. The magnetic field "encircles" each hole in the core which carries output wire **4**. This is similar to the threads of a screw "encircling" the shaft of the screw.

Within this generator, the magnetic field from output wire **4** immediately encircles each hole formed in the core (**c**). since wire **4** may take an opposing direction through each neighbouring hole, the direction of the resulting magnetic field will likewise be opposite. The direction of arrows (**b**) and (**c**) are, at each hole,

opposing, headed in opposite directions, since (b) is the inducing flux and (c) is the induced flux, each opposing one another while generating electricity.

However, this magnetic opposition is effectively directed against the permanent magnets which are injecting their flux into the core, but not the source of the alternating magnetic input field 6. In the present solid-state generator, induced output flux (4,c) is directed to oppose the permanent magnets (1,2) not the input flux source (6, a) which is synthesising the virtual motion of those magnets (1,2) by it's magnetising action on core 3.

The present generator employs magnets as the source of motive pressure driving the generator, since they are the entity being opposed or "pushed against" by the opposing reaction induced by output current which is powering a load. Experiments show that high-quality permanent magnets can be magnetically "pushed against" in this way for very long periods of time, before becoming demagnetised or "spent".

Fig.3 illustrates inducing representative flux arrows (b) directed oppositely against induced representative flux (c). In materials typically used to form core 3, fields flowing in mutually opposite directions tend to cancel each other, just as positive and negative numbers of equal magnitude sum to zero.

On the remaining side of each hole, opposite the permanent magnet, no mutual opposition takes place. Induced flux (c) caused by the generator load current remains present; however, inducing flux from the permanent magnets (b) is not present since no magnet is present, on this side, to provide the necessary flux. This leaves the induced flux (c) encircling the hole, as well as input flux (a) from the input coils 6, continuing its path along the core, on either side of each hole.

On the side of each hole in the core where a magnet is present, action (b) and reaction (c) magnetic flux substantially cancel each other, being directed in opposite directions within the core. On the other side of each hole, where no magnet is present, input flux (a) and reaction flux (c) share a common direction. Magnetic flux adds together in these zones, where induced magnetic flux (c) aids the input flux (a). This is the reverse of typical generator action, where induced flux (c) is typically opposing the "input" flux originating the induction.

Since the magnetic interaction is a combination of magnetic flux opposition and magnetic flux acceleration, there is no longer an overall magnetic braking or total opposition effect. The braking and opposition is counterbalanced by a simultaneous magnetic acceleration within the core. Since mechanical motion is absent, the equivalent electrical effect ranges from idling, or absence of opposition, to a strengthening and overall acceleration of the electrical input signal (within coils 6). proper selection of the permanent magnet (1,2) material and flux density, core 3 material magnetic characteristics, core hole pattern and spacing, and output medium connection technique, create embodiments where the present generator will display an absence of electrical loading at the input and/or an overall amplification of the input signal. this ultimately causes less input energy to be required in order to work the generator. Therefore, as increasing amounts of energy are withdrawn from the generator as output power performing useful work, decreasing amounts of energy are generally required to operate it. This process continues, working against the permanent magnets (1,2) until they are demagnetised.

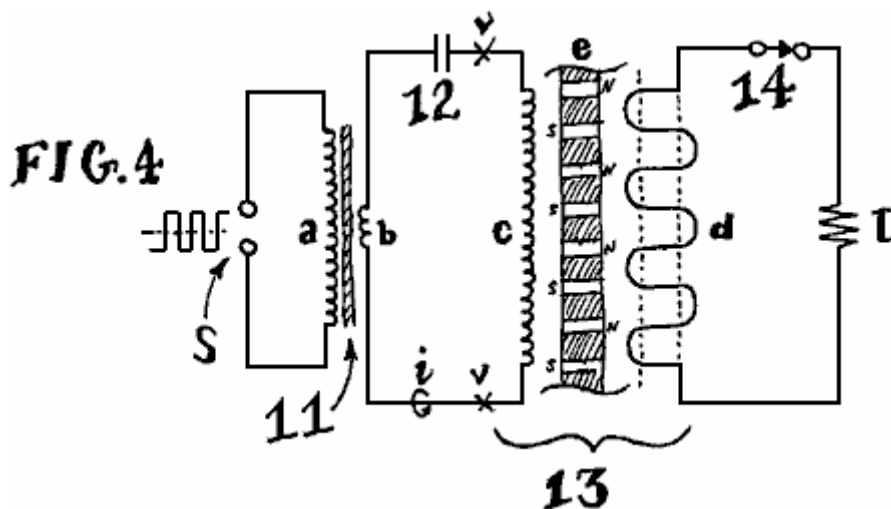

In an embodiment of this invention, **Fig.4** illustrates a typical operating circuit employing the generator of this invention. A square-wave input signal from a transistor switching circuit, is applied at the input terminals (**S**), to the primary (**a**) of a step-down transformer **11**. The secondary winding (**b**) of the input transformer may be a single turn, in series with a capacitor **12** and the generator **13** input coil (**c**), forming a series resonant circuit. The frequency of the applied square wave (**S**) must either match, or be an integral sub-harmonic of the resonant frequency of this 3-element transformer-capacitor-inductor input circuit.

Generator **13** output winding (**d**) is connected to resistive load **L** through switch **14**. When switch **14** is closed, generated power is dissipated at **L**, which is any resistive load, for example, and incandescent lamp or resistive heater.

Once input resonance is achieved, and the square-wave frequency applied at **S** is such that the combined reactive impedance of total inductance (**b + c**) is equal in magnitude to the opposing reactive impedance of capacitance **12**, the electrical phases of current through, and voltage across, generator **13** input coil (**c**) will flow 90 degrees apart in resonant quadrature. Power drawn from the square-wave input energy source applied to **S** will now be at a minimum.

In this condition, the resonant energy present at the generator input may be measured by connecting a voltage probe across the test points (**v**), situated across the generator input coil, together with a current probe around point (**l**), situated in series with the generator input coil (**c**). The instantaneous vector product of these two measurements indicates the energy circulating at the generator's input, ultimately shifting the permanent magnets' fields in order to create useful induction. This situation persists until the magnets are no longer magnetised.

It will be apparent to those skilled in the art that a square (or other) wave may be applied directly to the generator input terminals (**c**) without the use of other components. While this remains effective, advantageous re-generating effects may not be realised to their fullest extent with such direct excitation. Use of a resonant circuit, particularly with inclusion of a capacitor **12** as suggested, facilitates recirculation of energy within the input circuit, generally producing efficient excitation and a reduction of the required input power as loads are applied.

Charles Flynn

The technique of applying magnetic variations to the magnetic flux produced by a permanent magnet is covered in detail in the patents of Charles Flynn which are shown in the "PatD20" document in this set. In his patent he shows techniques for producing linear motion, reciprocal motion, circular motion and power conversion, and he gives a considerable amount of description and explanation on each, his main patent containing a hundred illustrations. Taking one application at random:

He states that a substantial enhancement of magnetic flux can be obtained from the use of an arrangement like this:

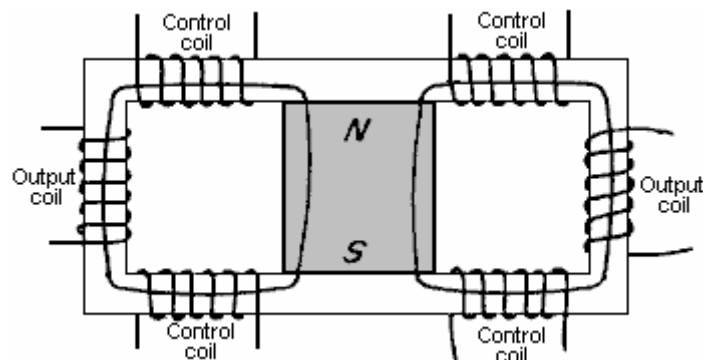

Here, a laminated soft iron frame has a powerful permanent magnet positioned in it's centre and six coils are wound in the positions shown. The magnetic flux from the permanent magnet flows around both sides of the frame.

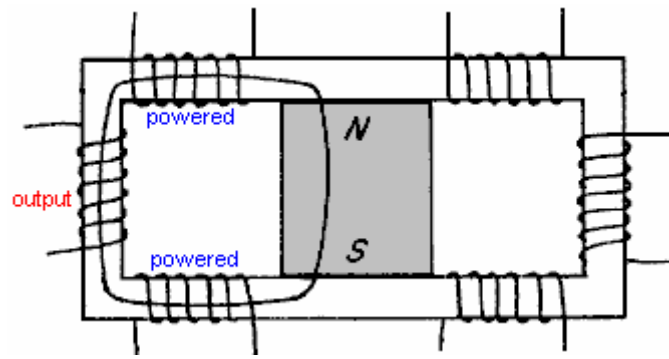

When the left hand control coils are powered so that the magnetic field generated adds to that of the permanent magnet already flowing around that side of the frame, Charles states that all of the permanent magnet's flux gets diverted to the left hand frame circuit. This causes the flux on that side to rise by half of that of the permanent magnet plus all of the electromagnetic flux. In effect, the magnetic variation is greater than the magnetic field generated by the current in the coil. In other words, applying a current to the coil produces an enhanced magnetic effect, thanks to the permanent magnet. The components should be arranged so that the frame does not get saturated at peak current.

The control circuitry then alters the coil drive to:

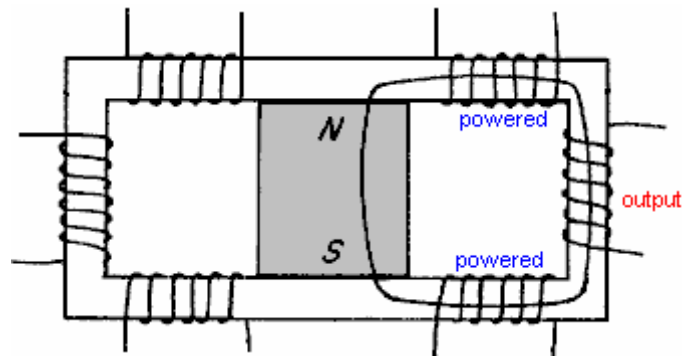

and the same effect takes place on the other side of the frame. The indications are that this is a very effective method of power conversion.